



## NFF BRAKE

FOR COMPACT INDUSTRIAL  
AND CRANE APPLICATIONS WITH  
A HIGH PROTECTION AGAINST  
HARSH ENVIRONMENTS



# Stromag

Founded in 1932, Stromag has grown to become a globally recognized leader in the development and manufacture of innovative power transmission components for industrial drivetrain applications. Stromag engineers utilize the latest design technologies and materials to provide creative, energy-efficient solutions that meet their customer's most challenging requirements.

Stromag's extensive product range includes flexible couplings, disc brakes, limit switches, an array of hydraulically, pneumatically, and electrically actuated brakes, and a complete line of electric, hydraulic and pneumatic clutches.

Stromag engineered solutions improve drivetrain performance in a variety of key markets including energy, off-highway, metals, marine, transportation, printing, textiles, and material handling on applications such as wind turbines, conveyor systems, rolling mills, agriculture and construction machinery, municipal vehicles, forklifts, cranes, presses, deck winches, diesel engines, gensets and stage machinery.



VISIT US ON THE WEB AT [STROMAG.COM](http://STROMAG.COM)

VISIT US ON THE WEB AT [REGALREXNORD.COM](http://REGALREXNORD.COM)



# NFF – Electromagnetic Spring-Applied Brake

## Applications

- Holding- and Working brake variations for industrial applications
- Usable for dockside-, harbour and marine crane brake suitable for seawater environment

## Standard features

Coil body with coil	Thermal class 155, nitrocarburated and postoxidated
Outer body	Manufactured in sea water proof aluminium with large inspection holes prepared for hand release lever with sealed bearings
Armature plate	Special protection: nitrocarburated and postoxidated
Brake flange	Special protection: nitrocarburated and postoxidated
Friction lining	Low wear rate with low torque fade over a high range of temperature. High thermal capacity
End Cover	Manufactured in sea water proof aluminium with provision for standstill heater
Hub	Nitrocarburated and postoxidated
Fixings screws	All stainless steel
Flying leads	1 metre long
Seals	For high protection

## Optional extras

- Simple adjustment with adjusting ring
- Hand release lever
- Tacho / Endcover provision
- Terminal box
- Micro switch to monitor switching states or wear monitoring
- Standstill heater

## Switching modules

- Half wave or full wave
- Quick switching units
- Built in terminal box
- Attached for mounting into the motor terminal box

# NFF – Electromagnetic Spring-Applied Brake

---

## Advantages

- Comprehensive range 20 - 10,000 Nm
- Simple assembly to motor, no dismantling of brake required
- Concentricity through body for tacho fixing
- No setting required when changing armature disc and friction disc
- Compatibility of consumable spares
- Simple maintenance, once only adjustment by shim removal
- Positive feel hand release mechanism
- Proven reliable design
- Sealed inspection holes for air gap or lining wear
- Extremely low inertia
- High heat dissipation
- Free from axial loads when braking and running
- Suitable for vertical mounting, please consult Stromag Dessau GmbH
- Many optional extras available
- Facilities to design to customer's special requirements
- Protection available up to IP 66 (in installed state)
- "Asbestos free" linings as standard

## Voltages available

- Voltages: 24 V DC, 103 V DC, 190 V DC and 207 V DC, other voltages (e.g. 110 V DC) on request.
- Coils available to suit: AC – supplies with integral Half and Full wave rectification.
- We suggest the following alternative – Customer to take standard voltage with rectifier which Stromag can provide.

# NFF – Electromagnetic Spring-Applied Brake

## Designation of individual components

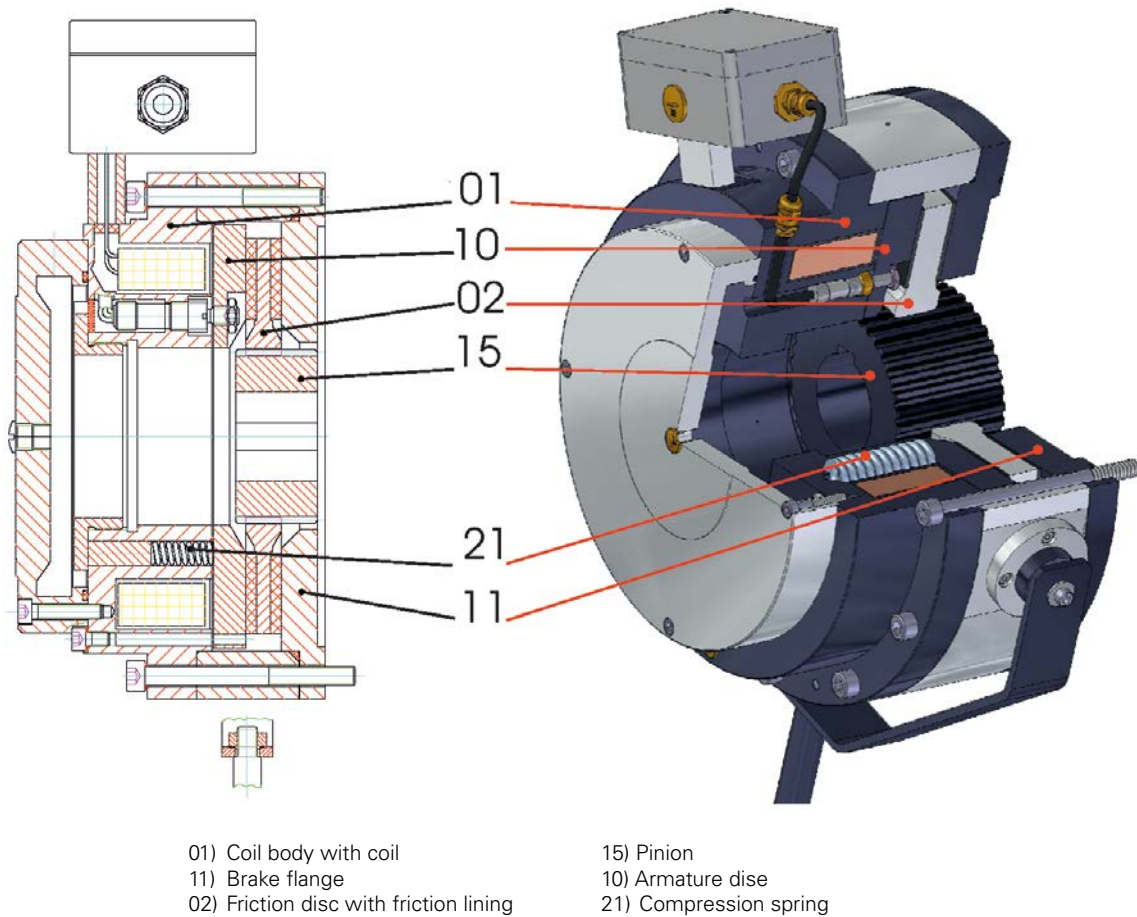

## Brake operation

Brakes should be switched on the DC side. (This will achieve fastest response times).

Brakes are fail-safe i.e. Spring-Applied. Power on to release.

When the coil is energized, the magnetic flux attracts the armature disc (10) to the coil body, this compresses the springs (21) and releases the friction disc with friction lining (02) and the brake is released.

When the coil is de-energized the compression springs (21) push the armature disc (10) axially against the friction disc with friction lining (02). This is clamped between the armature disc (10) and the brake flange (11) thereby preventing rotation. The braking effect is transmitted through the friction disc with friction lining (02) to the shaft by way of a splined driving hub (15).

# NFF – Electromagnetic Spring-Applied Brake

---

## Micro switch

Optional availability, Inboard Proving Switch, one common contact, one normally open contact and one normally closed contact.

This can be interlocked with motor contactor for parking brake duty, ie. brake release before starting motor.

## Brake termination

Three standard versions:

- Flying leads, usually 1 meter long through PG cable gland in coil body.
- IP 66 Terminal box, for easy connection and removal,
- Versions for AC supply with built-in full wave or half wave rectification inside the terminal box.

## Emergency hand release lever

No setting is required over maximum lining wear, special bearing mechanism for easy operation and positive feel, emergency jacking screws available if hand release lever not supplied.

## Brake flange

Manufactured to suit our brake and your motor.

## Standstill heater

Inboard standstill heater can be provided.

## Tacho / Encoder

Connections for Tacho / Encoder can be provided as optional extras.

## Special surface finishes

Most of the components can be treated with a protective surface coating for arduous environments; e.g. Dockside Cranes / Deck mounting etc.

# NFF – Electromagnetic Spring-Applied Brake

## List of dimensions

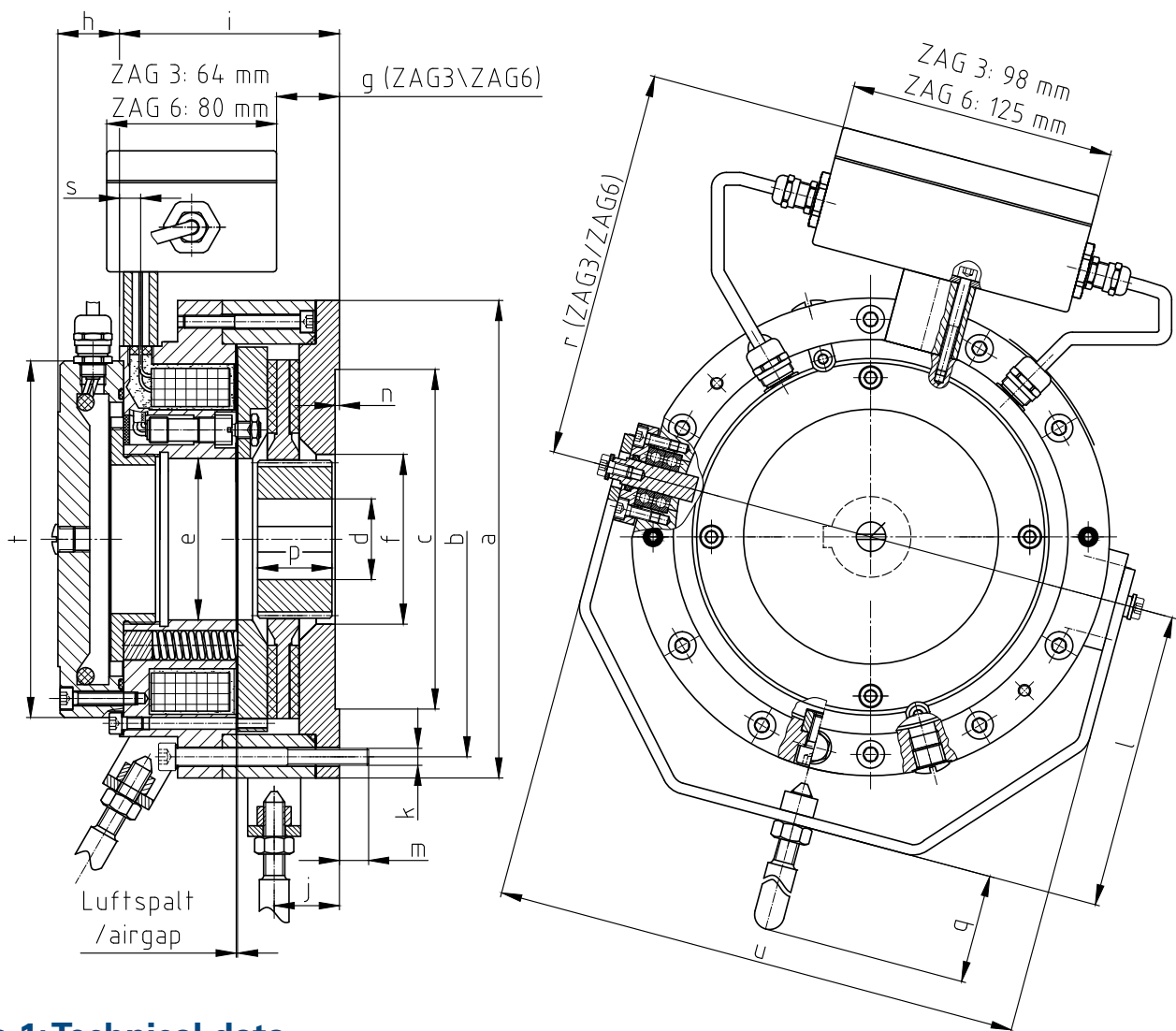

**Table 1: Technical data**

Size NFF	$M_{SN}$ Nm	$M_{\bar{U}}$ Nm	$n_o$ rpm	$n_{zn}$ rpm <sup>-1</sup>	$U_n^*$ V DC	$P_k$ W	airgap min/max	W kJ	$P_{vn}$ kW	J kgm <sup>2</sup>	m kg
2	20	22	5300	3000	103	89.9	0.6/1.0	25	0.080	0.0004	6.3
4	40	44	4900	3000	103	90.7	0.6/1.0	30	0.067	0.00043	10.4
6.3	63	70	6500	3000	103	113.9	0.6/1.2	65	0.103	0.0008	13
10	100	110	6500	2500	103	110.4	0.6/1.2	75	0.110	0.00125	14
16	160	175	6000	2400	103	115.8	0.6/1.2	120	0.124	0.0034	21
25	250	275	5600	2100	103	136.6	0.6/1.2	150	0.149	0.0043	30
40	400	440	4900	1800	103	212.9	0.6/1.3	250	0.170	0.01212	38
63	630	700	4500	1500	103	227.3	0.6/1.5	320	0.249	0.01463	58
100	1000	1100	3900	1300	103	277.6	0.6/1.6	450	0.270	0.04171	85.5
160	1600	1750	3200	1000	103	353.5	0.6/1.6	450	0.325	0.14821	133
250	2500	2750	2800	900	207	367.0	0.6/1.8	700	0.400	0.23515	157
400	4000	4400	2400	800	207	400.9	0.6/1.8	750	0.482	0.43412	286
630	6300	7000	2100	700	207	489.6	0.6/1.8	820	0.601	1.01607	363
1000	10000	11000	1800	650	207	535.5	0.6/2.1	1030	0.587	1.56099	612

\* other voltages on request

# NFF – Electromagnetic Spring-Applied Brake

$M_{SN}$	Switchable nominal torque at 1m/s frictional speed to DIN VDE 0580 (applies to dry operation with an oil- and grease-free friction lining after running-in)
$M_{\dot{U}}$	Transmissible static nominal torque without slip, to DIN VDE 0580 (applies to dry operation with an oil- and grease-free friction lining after running-in)
$n_0$	Maximum idling speed
$n_{zn}$	Admissible switching speed
$P_k$	Excitation output at 20°C
$P_{vn}$	Nominal braking capacity (S4-40 % I.O.)
$W$	Switch work per switching operation for $z = 1 - 5h^{-1}$
$J$	Mass moment of inertia of rotating parts
$m$	Weight
Mode of operation	S1, S2, S4-40 % I.O.
Thermal class	155 (F) in accordance with DIN VDE 0580
AC-control	Via rectifier

**Table 2: List of dimensions (all dimensions in mm)**

Size NFF	2	4	6.3	10	16	25	40	63	100	160	250	400	630	1000
a	150	165	175	190	225	250	270	314	350	440	500	560	650	750
b	135	152	162	175	190	225	250	292	325	418	472	530	620	710
cH 8	120	140	140	160	180	200	220	240	270	340	390	460	530	600
dH 7	25	30	40	40	45	50	60	60	80	110	120	130	140	160
e	53	55	55	65	76	78.5	90	96	125	200	215	240	270	300
f	47	80	80	65	80	90	105	120	158	220	255	280	320	330
$g_{ZAG\ 3}$	15	29	32.6	36	44	61	81	82.6	108	-	-	-	-	-
$g_{ZAG\ 6}$	-	15	18.6	22	30	47.2	67	68.6	94	108.8	116.7	152	148.2	188.4
h	30	33	29	27	29	30	32	32	32	33	30	33	33	32
i	73.5	89.6	94.6	96	104	121	141	145	168	182.6	191	226	225	265
j	20.9	28	29	29	32	39	40	45	54	57	-	-	-	-
k (6x)	M5	M6	M6	M6	M8	M8	M8	M10	M10	M12	M16	M16	M16	M20
l	95	110	110	123	140	150	170	200	220	290	-	-	-	-
m	10.5	7.8	13	14	14	13	14.2	19.5	19	24.4	21.4	26.3	30	30
n	2.5	2.5	2.5	3.5	3.5	3.5	4	4	5	5.5	5	5	6	6
p	24	28	30	30	35	45	45	55	75	125	130	150	185	210
q	110	110	110	110	110	150	150	250	500	95	-	-	-	-
$r_{ZAG\ 3}$	113.5	122	126.5	140	157	163	177	194	212	-	-	-	-	-
$r_{ZAG\ 6}$	-	145	149.5	163.5	178	186	199	217	234.5	285.5	312.5	344.5	384	437
s	8.5	10.5	10	10	10	10	10	12	10	10	10	10	10	10
t	123	140	150	146	168	172	184	230	255	255	255	320	320	400
u	179.5	198	201	216	251	276	300	343	408	480	-	-	-	-

Keyways to DIN 6885/1



# NFF – Electromagnetic Spring-Applied Brake

## Optional accessories

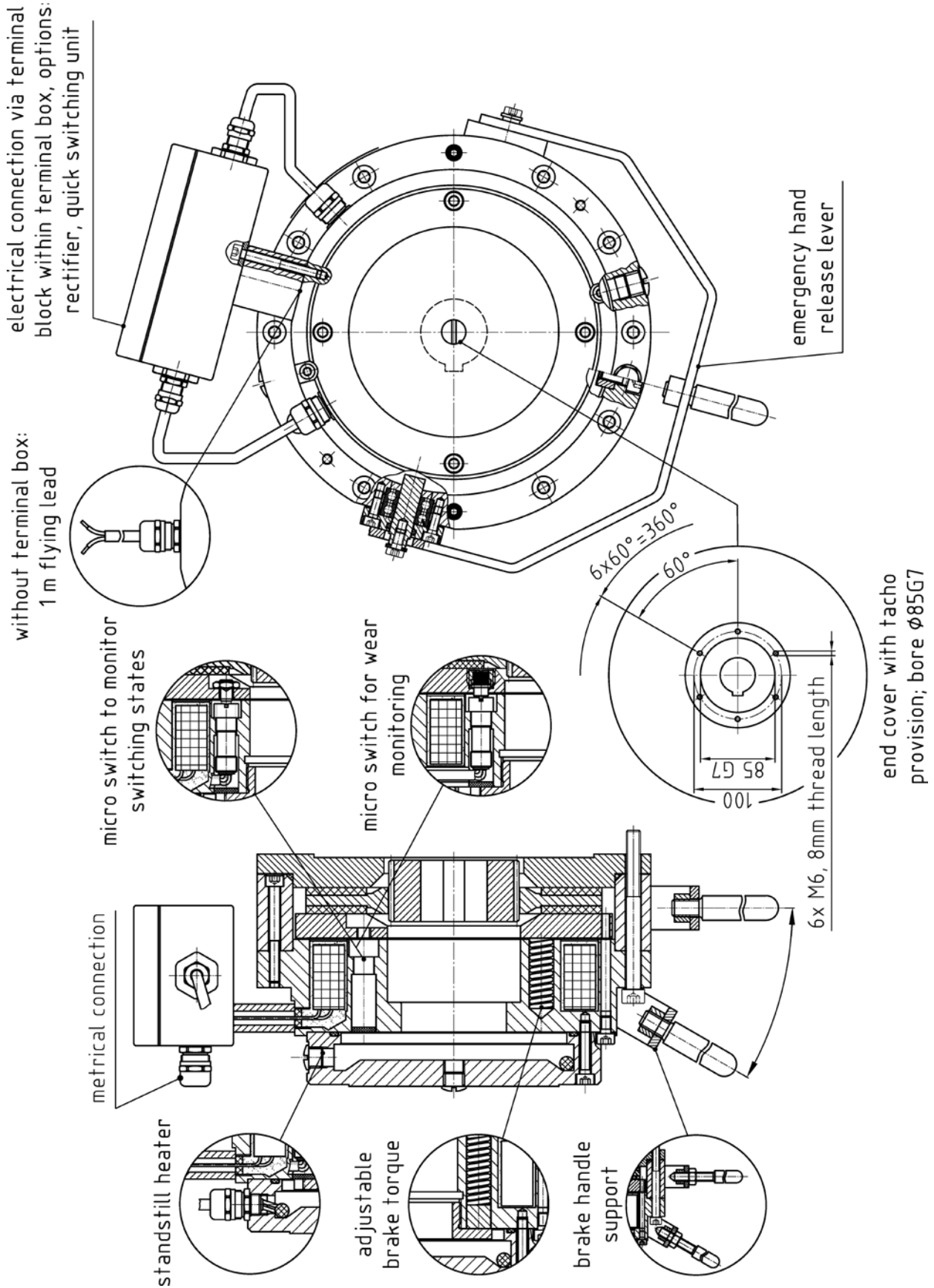

# NFF – Electromagnetic Spring-Applied Brake

## Example of designation

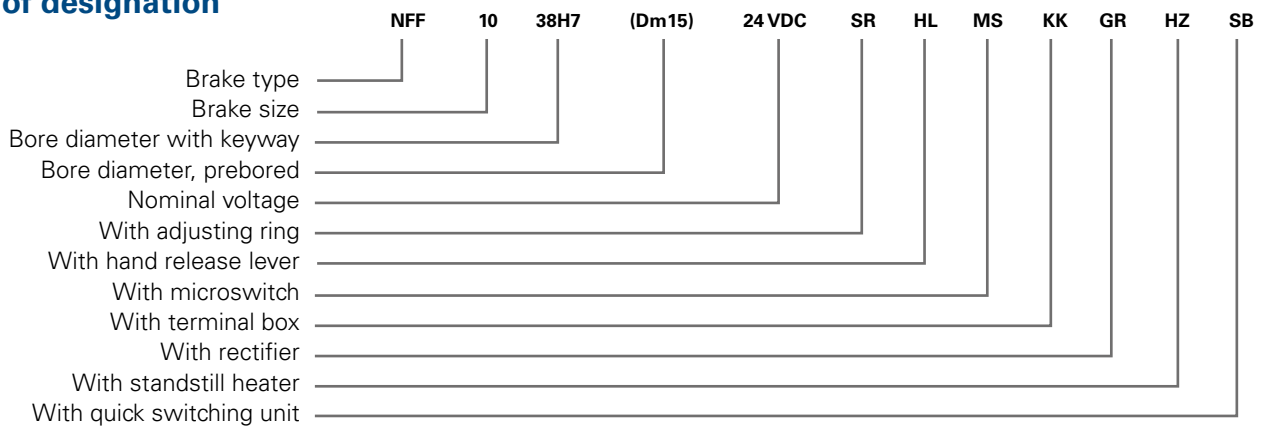

## Calculations

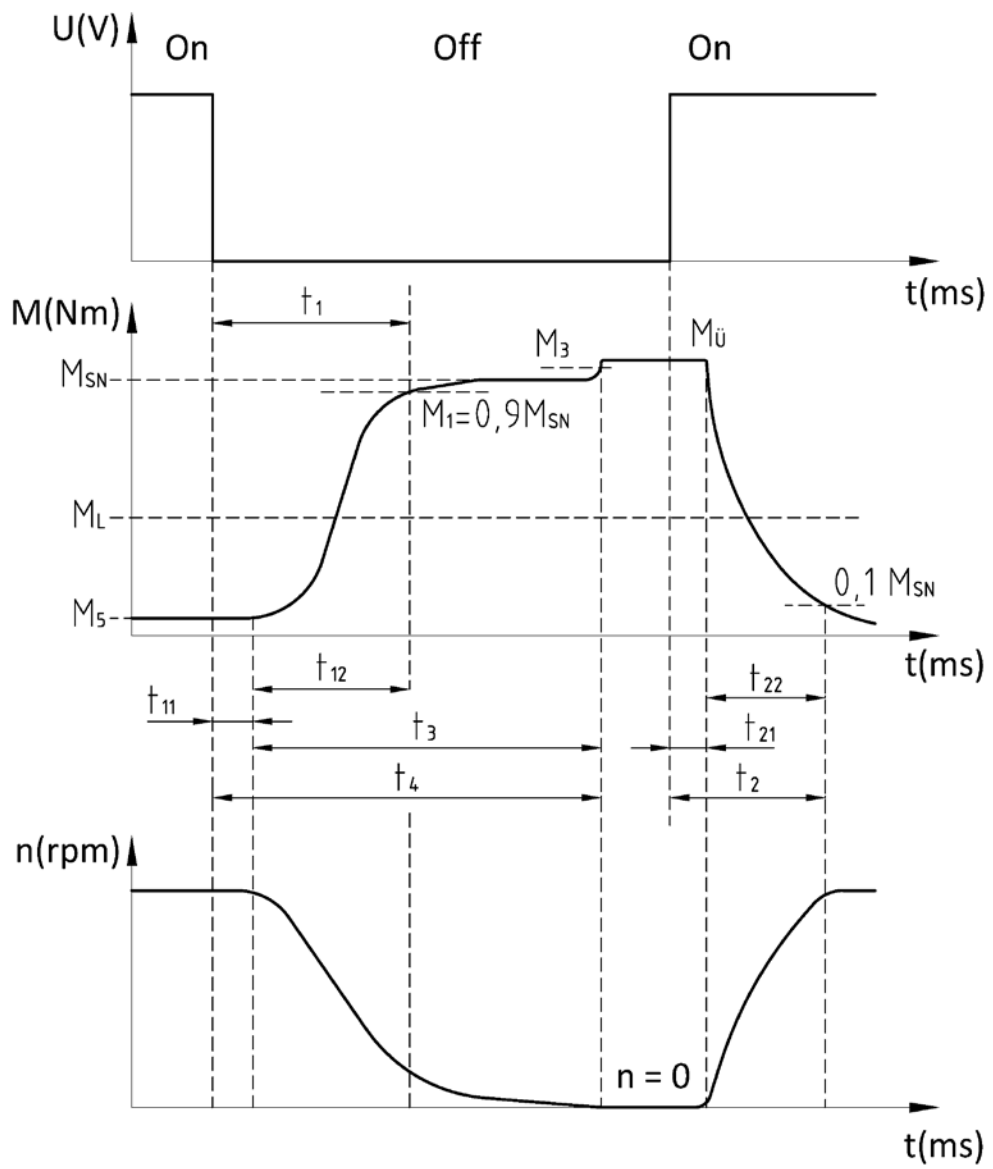

Figure 1: The diagram shows the time response of an Electromagnetic Spring-Applied Brake as defined by VDE regulations 0580

## **$M_1$ = Switchable torque [Nm]**

The switchable (dynamic) torque is the torque which can be transmitted by a brake under slip condition depending on the friction coefficient and at working temperature. ( $M_1 = 0,9M_{SN}$ )

## **$M_3$ = Synchronization torque [Nm]**

The synchronization torque is the torque which arises for a short time after finishing the switching process.

## **$M_u$ = Transmissible torque [Nm]**

The transmissible (static) torque is the max. torque that can be applied to a brake without the risk of slipping.

## **$M_{SN}$ = Switchable nominal torque [Nm]**

The switchable nominal torque is the dynamic torque as stated in the catalogue at a frictional speed of 1 m/sec.

## **$M_L$ = Load torque [Nm]**

+  $M_L$  for acceleration, –  $M_L$  for deceleration. The load torque should always be considered with relative safety factors.

## **$M_5$ = No-load torque (drag torque) [Nm]**

The no-load torque is the torque which the brake transmits at working temperature when free running.

## **$M_A$ = Decelerating torque [Nm]**

The decelerating torque results from the addition (subtraction for lifting gear during lowering) of the switchable torque and load torque.

## **Operation times**

The operation times shown in the diagram are based on the example of a brake actuated by loss of electrical current. The basic characteristic is also applicable to brakes with alternate methods of operation. The time delay  $t_{11}$  is the time from the instant of de-energization (actuation) to the commencement of the torque build-up (of no importance for d.c. switching). The torque build-up time  $t_{12}$  is the time from the commencement of torque build-up to the attainment of 90% of the switchable nominal torque  $M_{SN}$ . The switching time  $t_1$  is the sum of the time delay and torque build-up time:

$$t_1 = t_{11} + t_{12}$$

The time delay  $t_{21}$  is the time from energization (actuation) to the commencement of the torque will decrease. The fall time  $t_{22}$  is the time from the commencement of the torque decrease to 10% of the switchable nominal brake torque  $M_{SN}$ . The switching time  $t_2$  is the sum of the time delay and the fall time:

$$t_2 = t_{21} + t_{22}$$

To decrease the switching times of Electromagnetic Spring-Applied brakes, special switching is required.

Please ask for particular information. The switching times stated in the dimensional tables apply to d.c. switching, working temperature and nominal voltage without special switching techniques.

# NFF – Electromagnetic Spring-Applied Brake

---

## Nomenclature

$A_R$	cm <sup>2</sup>	Friction surface		
$m$	kg	Mass		
$Q$	Joule(J)	Heat quantity		
$Q_h$	Watt(W)	Heat per hour		
$c$	$\frac{kJ}{kgK}$	Specific heat	Steel $c = 0,46 \frac{kJ}{kgK}$	Cast iron $c = 0,54 \frac{kJ}{kgK}$
$n$	rpm	Speed		
$t_A$	s	Braking time		
$t_S$	s	Slipping time		

## Mass moment of inertia J [kgm<sup>2</sup>]

The mass moment of inertia J stated in the formula is the total mass moment of inertia of all the masses to be retarded referred to the brake.

## Reduction of moments of inertia

The reduction of moments of inertia is calculated from the formula

$$J_1 = J_2 * \left(\frac{n_2}{n_1}\right)^2 \quad [kgm^2]$$

## Moments of inertia of linear masses

The equivalent moment of inertia  $J_{Ers}$  for a linear mass  $m$  and a velocity  $v$  referred to the brake speed  $n$  is calculated from the formula

$$J_{Ers} = 91 * m \left(\frac{v}{n}\right)^2 \quad [kgm^2]$$

[ $v = m/s$ ]    [ $n = min^{-1}$ ]    [ $m = kg$ ]

## Torque considerations for the brake

The mean torque of the driving or driven machine may be calculated from

$$M = 9550 * \frac{P}{n} \quad [Nm]$$

[ $P = kW$ ]    [ $n = rpm$ ]

If the system includes gearing, all torques must be referred to the brake shaft. Depending on the type and functioning of the driving or driven machine resp. shock and peak loads are an important factor for the determination of brake sizes. If precise deceleration times are required a sufficient decelerating torque must already been taken into account when selecting the brake size on the torque rating. Considering the load torque direction, the following switchable nominal torque  $M_{SN}$  of a brake is attained (+ $M_L$  for lifting devices when lowering).

# NFF – Electromagnetic Spring-Applied Brake

Acceleration by load	Brake support by load
$M_{SN} = M_A + M_L$	$M_{SN} = M_A - M_L$

When expressing the decelerating torque  $M_A$  by means of the pulse principle, we obtain after corresponding conversion.

Acceleration by load	Brake support by load
$M_A = J * \frac{d\omega}{dt} \quad [\text{Nm}]$	$M_A = J * \frac{d\omega}{dt} \quad [\text{Nm}]$
$M_{SN} = J * \frac{J * n}{9,55 * t_A} + M_L \quad [\text{Nm}]$	$M_{SN} = J * \frac{J * n}{9,55 * t_A} - M_L \quad [\text{Nm}]$
$t_A = \frac{J * n}{9,55 * (M_{SN} - M_L)} \quad [\text{s}]$	$t_A = \frac{J * n}{9,55 * (M_{SN} + M_L)} \quad [\text{s}]$

It is assumed that the dynamic torque is achieved instantaneously. Note that the dynamic torque decreases with the speed.

## Considerations of dissipated energy

For all operations at speed with slip, dissipated energy is generated in the brake which is transformed into heat. The admissible amount of dissipated energy resp. power capacity must not be exceeded in order to avoid any inadmissible heating. Often the selection of the brake size upon the torque requirement only is not sufficient. Therefore it must always be checked whether the heat capacity of the brake is sufficient.

Generally the dissipated energy in a brake, slipping at time  $dt$  with its dynamic torque  $M_s$  at an angular speed  $\omega_s$  is:

$$dQ = M_s * \omega_s * dt$$

With  $\omega_s$  and conversion by means of the pulse principle the following dissipated energy amount is determined for a single deceleration process with existing load torque

Acceleration by load	Brake support by load
$Q = \frac{M_{SN}}{(M_{SN} - M_L)} * \frac{J * n^2}{182.000} \quad [\text{kJ}]$	$Q = \frac{M_{SN}}{(M_{SN} + M_L)} * \frac{J * n^2}{182.000} \quad [\text{kJ}]$

If a brake slips with constant slipping speed under operation, the dissipated energy is calculated from the formula

$$Q = 0,105 * 10^{-3} * M_s * n_s * t_s \quad [\text{kJ}]$$

## Working brake

The brake has to brake a shaft with switching frequency "X" from speed "Y" to speed zero and has to hold it.

## Holding brake with emergency stop function

The brake actuates with shaft speed zero and has to hold; in case of emergency, however, it must be able to brake from shaft speed "Y" to zero.

# NFF – Electromagnetic Spring-Applied Brake

## Permissible heat capacity at 1500 rpm

W [kJ] Switching operations  $z \left[ \frac{1}{h} \right]$  operations per hour

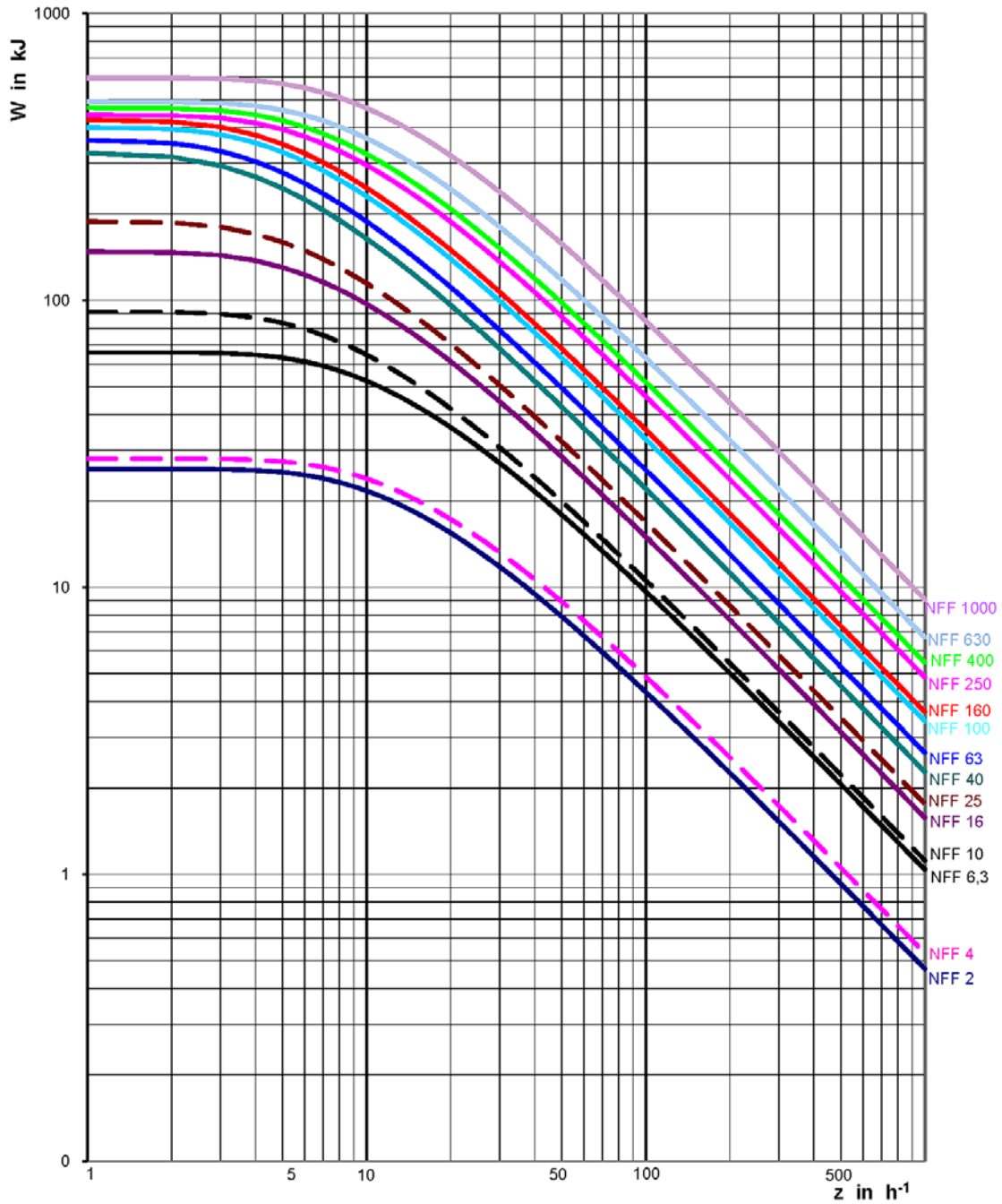

Figure 2: Heat capacity of series NFF n =1500 rpm \*\*.  
By known operations and number of operations per hour the brake size can be obtained.

Example: W = 100 kJ/operation and z = 10 operations/hour choose the size NFF 25

\*\* permissible switching operations per switching at other speed ratings on request

# NFF – Electromagnetic Spring-Applied Brake

## Questionnaire to allow the determination of Spring-Applied Brakes

### DRIVING MACHINE

Frequency controlled motor		
Pole changing motor		
Constant speed motor		
Other motor types		
Nominal and maximum power		kW
Nominal and maximum speed		rpm
Maximum torque (i.e. breakdown torque)		Nm

### DRIVEN MACHINE

Slewing system		
Hoisting system		
Trolley or gantry system		
Winch system		
People transporting system		
Other application		

### BRAKE TYPE

Working and emergency brake		
Holding brake with emergency characteristic		

### CALCULATION DATA

Nominal braking speed		rpm
Emergency braking speed (i.e. max. possible overspeed at hoisting drives)		rpm
Load torque at nominal braking speed		Nm
Load torque at emergency braking speed		Nm
Maximum possible load torque		Nm
Number of braking operations per hour at nominal / required speed (incl. load data)		
Number of braking operations per required time unit at emergency speed (incl. maximum load data)		
Moment of inertia of the parts moved by the motor or braked by the brake (motor, gearbox, winch etc.)		kgm <sup>2</sup>
Demanded switching cycles of the brake		
Ambient temperature		°C
Protection class or short description of environmental conditions Marine, port, in house		
Options: Microswitch, rectifier, switching unit, terminal box, heater or other		

## Stromag Facilities

### Europe

#### Germany

Hansastraße 120  
59425 Unna - Germany  
+49 (0) 23 03 102 0

Clutches & Brakes, Couplings,  
Geared Cam Limit Switches, Discs

#### France

Avenue de l'Europe  
18150 La Guerche sur L'Aubois -  
France  
+33 (0)2 48 80 72 72

Disc Brakes & Drum Brakes

#### Great Britain

Amphill Road  
Bedford, MK42 9RD - UK  
+44 (0)1234 324347

Electromagnetic Clutches & Brakes,  
Industrial Caliper Brakes

### North America

#### USA

31 Industrial Park Road  
New Hartford, CT 06057 - USA  
860-238-4783

Electromagnetic Clutches & Brakes

300 Indiana Highway 212  
Michigan City, IN 46360 – USA  
219-874-5248

Couplings

2800 Fisher Rd.  
Wichita Falls, TX 76302 - USA  
940-723-3400

Geared Cam Limit Switches,  
Industrial Caliper & Drum Brakes

#### South America

##### Brasil

Avenida João Paulo Ablas, 2970  
Jardim da Glória, Cotia - SP,  
06711-250 - Brasil  
+55 (11) 4615-6300

Flexible Couplings, Bearing  
Isolators, and Coupling Guards

### Asia Pacific

#### China

T40B -5, No. 1765 Chuan Qiao Road  
Pudong 201206, Shanghai - China  
Tel +86 21-60580600

Clutches & Brakes, Electromagnetic  
Clutches & Brakes, Couplings, Indus-  
trial Caliper & Drum Brakes, Discs,  
Geared Cam Limit Switches

#### India

Gat No.: 448/14, Shinde Vasti,  
Nighoje  
Tal Khed, Pune- 410 501  
+91 2135 622100

Clutches & Brakes, Electromagnet-  
ic Clutches & Brakes, Couplings,  
Industrial Caliper & Drum Brakes,  
Discs, Geared Cam Limit Switches,  
Wind Brakes

### Renewable Energy

#### Denmark

Jernbanevej 9  
5882 Vejstrup  
+45 63 255 255

Wind Brakes

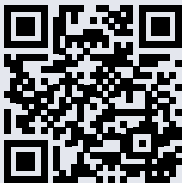

Scan to see all  
the brands of  
Regal Rexnord

Neither the accuracy nor completeness of the information contained in this publication is guaranteed by the company and may be subject to change in its sole discretion. The operating and performance characteristics of these products may vary depending on the application, installation, operating conditions and environmental factors. The company's terms and conditions of sale can be viewed at <http://www.altramotion.com/terms-and-conditions/sales-terms-and-conditions>. These terms and conditions apply to any person who may buy, acquire or use a product referred to herein, including any person who buys from a licensed distributor of these branded products.

©2023 by Stromag LLC. All rights reserved. All trademarks in this publication are the sole and exclusive property of Stromag LLC or one of its affiliated companies.



## 4 BZFM Brake for Offshore and Marine Application, flood- and seawater-proof



# Stromag

Founded in 1932, Stromag has grown to become a globally recognized leader in the development and manufacture of innovative power transmission components for industrial drivetrain applications. Stromag engineers utilize the latest design technologies and materials to provide creative, energy-efficient solutions that meet their customer's most challenging requirements.

Stromag's extensive product range includes flexible couplings, disc brakes, limit switches, an array of hydraulically, pneumatically, and electrically actuated brakes, and a complete line of electric, hydraulic and pneumatic clutches.

Stromag engineered solutions improve drivetrain performance in a variety of key markets including energy, off-highway, metals, marine, transportation, printing, textiles, and material handling on applications such as wind turbines, conveyor systems, rolling mills, agriculture and construction machinery, municipal vehicles, forklifts, cranes, presses, deck winches, diesel engines, gensets and stage machinery.



VISIT US ON THE WEB AT **STROMAG.COM**

# Altra Industrial Motion

Altra is a leading global designer and manufacturer of quality power transmission and motion control products utilized on a wide variety of industrial drivetrain applications. Altra clutches and brakes, couplings, gearing and PT component product lines are marketed under the industries most well known manufacturing brands. Each brand is committed to the guiding principles of operational excellence, continuous improvement and customer satisfaction. Highly-engineered Altra solutions are sold in over 70 countries and utilized in a variety of major industrial markets, including food processing, material handling, packaging machinery, mining, energy, automotive, primary metals, turf and garden and many others.

Altra's leading brands include **Ameridrives**, **Bauer** Gear Motor, **Bibby** Turboflex, **Boston** Gear, **Delroyd** Worm Gear, **Formsprag** Clutch, **Guardian** Couplings, **Huco**, **Industrial** Clutch, **Inertia** Dynamics, **Kilian**, **Lamiflex** Couplings, **Marland** Clutch, **Matrix**, **Nuttall** Gear, **Stieber**, **Stromag**, **Svendborg** Brakes, **TB Wood's**, **Twiflex**, **Warner** Electric, **Warner** Linear and **Wichita** Clutch.

VISIT US ON THE WEB AT **ALTRAMOTION.COM**



# 4 BZFM – Electromagnetic Spring-Applied Brake

## Applications

- Holding and working brake variations for off shore and industrial applications where high protection against harsh environment is essential
- Usable for windlasses, anchor winches, shipboard cranes, cargo winches, trawler winches

## Main features

<b>Coil body with coil</b>	Thermal class 155, nitrocarburated and postoxidated
<b>Armature disc</b>	Special protection: nitrocarburated and postoxidated
<b>Brake disc</b>	Special protection: nitrocarburated and postoxidated
<b>Friction lining</b>	Low wear rate with low torque fade over a high range of temperature. High thermal capacity.
<b>Flange</b>	To IEC standard
<b>Cover</b>	Manufactured of gray cast, from size 400 of seawater protected aluminium
<b>Pinion</b>	Nitrocarburated and postoxidated
<b>Fixing screws</b>	All stainless steel
<b>Flying leads</b>	1,5 metre long, radial or axial
<b>Seals</b>	For high protection

## Optional extras

- Micro switch for monitoring switching states or wear detection
- Terminal box
- Standstill heater
- Preparation for speedometer installation

## Switching modules

- Half wave or full wave
- Quick switching units
- Built in terminal box
- Attached for mounting into the motor terminal box

## 4 BZFM – Electromagnetic Spring-Applied Brake

---

### Advantages

- Comprehensive torque range 63 – 11,000 Nm
- Operative without cover
- Type approvals: GL, LRS, ABS, DNV, BV, RR (on request)
- Simple assembly to motor, no dismantling of brake required
- Less wear
- Compatibility of consumable spares
- Simple maintenance, one time wear re-adjustment by reversing of the brake disc
- Proven reliable design
- Sealed inspection holes for air gap or lining wear
- Extremely low inertia
- High heat dissipation
- Free from axial loads when braking and running
- Suitable for vertical mounting, please consult Stromag Dessau GmbH
- Many optional extras available
- Facilities to design to customer's special requirements
- Protection available up to IP 67
- "Asbestos free" linings as standard

### Voltages available

- Usual voltage: 24 V DC, 110 V DC, 190 V DC and 207 V DC, other voltages (e.g. 103 V DC) on request.
- Coils available to suit: AC – supplies with integral Half and Full wave rectification.
- We suggest the following alternative - Customer to take standard voltage with rectifier which Stromag Dessau can provide.

# 4 BZFM – Electromagnetic Spring-Applied Brake

## Designation of individual components

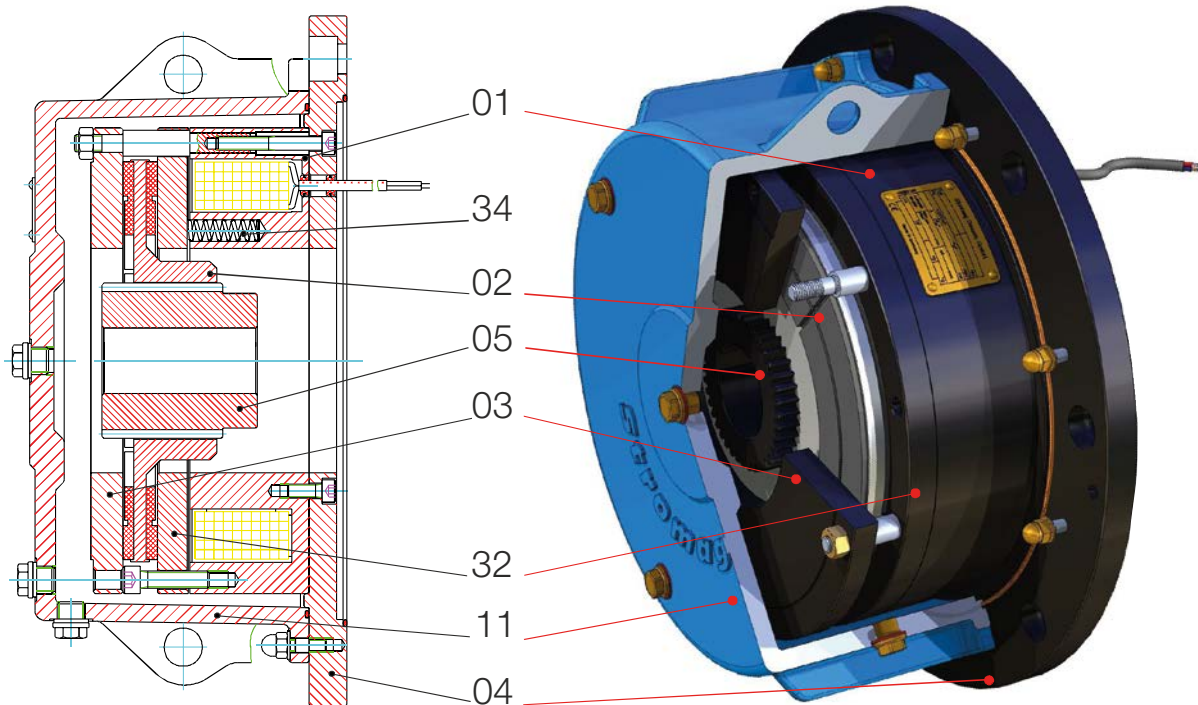

- |  |                        |
|--|------------------------|
| 01) Coil body                          | 11) Cover              |
| 02) Friction disc with friction lining | 32) Armature disc      |
| 03) Brake disc                         | 33) Coil               |
| 04) Flange                             | 34) Compression spring |
| 05) Pinion                             |                        |

## Brake operation

The brake 4 BZFM is a spring-loaded electromagnetic double-face brake which brakes without current and is released electromagnetically.

The brake is screwed to a motor or any other machine part by means of cyl. screws via the flange (04). The coil body (01) contains a coil (33) which is potted with a synthetic resin compound in accordance with thermal class 155, (max. limit of temperature 155°C).

If the coil (33) is not excited, the springs (34) press the armature disc (32) against the friction disc with friction lining (02), which is firmly clamped between the torsion-protected armature disc (32) and the brake disc (03) and thus prevented from rotating. The braking effect is transmitted from the geared friction disc with friction lining (02) via the pinion (05) and a fitting key to the shaft. If the coil is connected to a direct voltage as specified on the nameplate, the magnetic force will draw the armature disc (32) to the coil body (01) overcoming the spring pressure. The friction disc with friction lining (02) is released, the braking effect is cancelled and the brake is released.

## 4 BZFM – Electromagnetic Spring-Applied Brake

---

### Micro switch

Optional availability, inboard proving switch, one common contact, one normally open contact and one normally closed contact.

This can be interlocked with motor contactor for parking brake duty, i.e. brake release before starting motor.

### Brake termination

Three standard versions:

- Flying leads usually 1,5 meter long, axial with a cable bushing and radial through cable gland in flange.
- IP 66 terminal box, for easy connection and removal, at execution with terminal box the brake complies with protection IP 66!
- Versions for AC supply with built-in full wave or half wave rectification inside the terminal box.

### Emergency release by means of emergency release screws

For mechanical release in case of emergency or for the adjustment of the system emergency release screws are available.

### Flange to IEC

Manufactured to suit your motor on B-side to our brake with IEC connection dimensions.

### Standstill heater

Inboard standstill heaters can be provided.

### Speedometer installation

If a speedometer connection is required for the brake, the brake cover is provided with connecting bores in accordance with "Euro dimension". The type of protection only maintains when the speedometer is rigidly connected to the cover by means of a flange gland which is sealed by round ring.

### Special surface finishes

All components are surface finished with a special surface protection against abrasive environment; e.g. against saline atmosphere on deck, etc..

# 4 BZFM – Electromagnetic Spring-Applied Brake

## List of dimensions

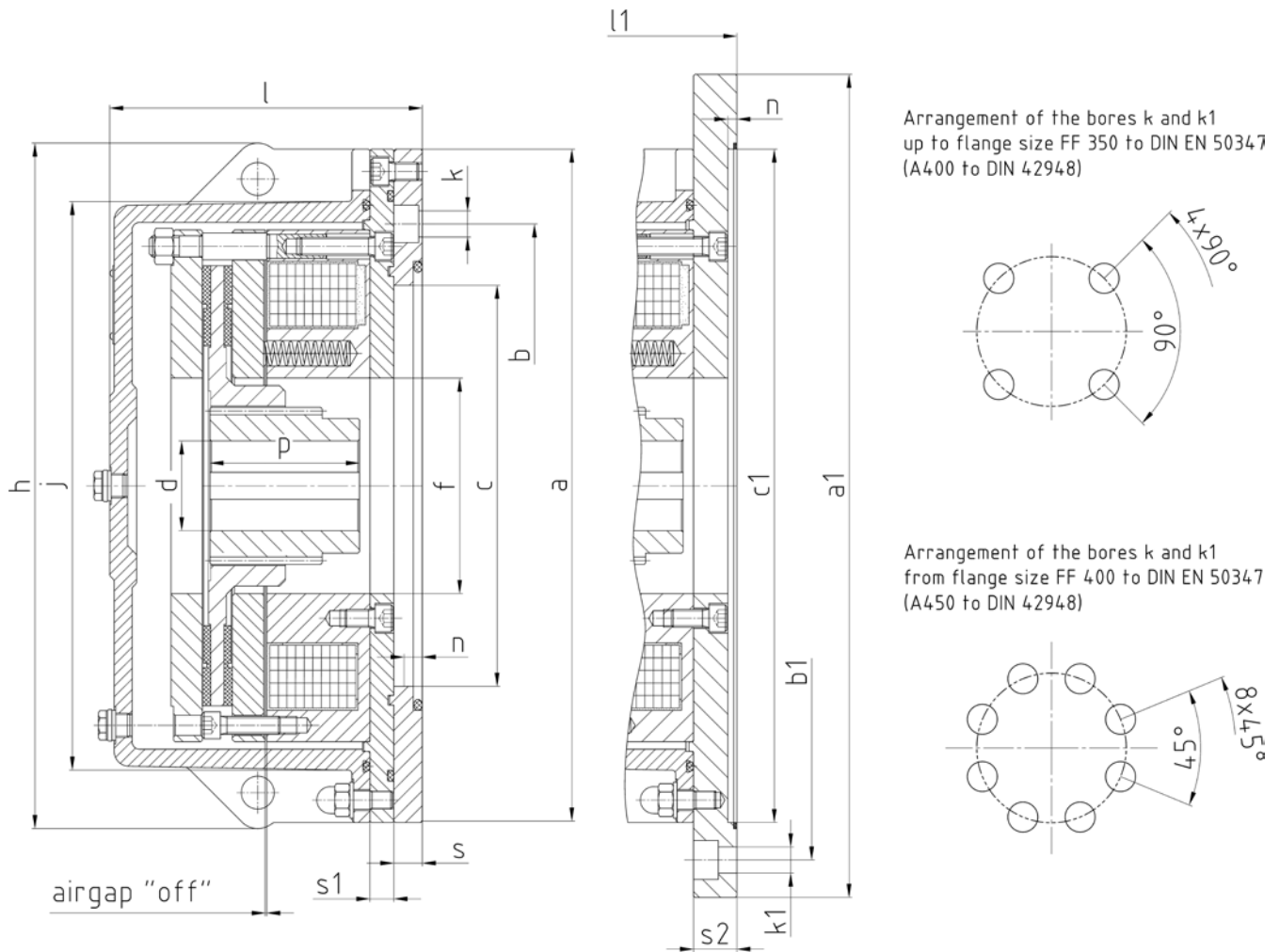

**Table 1: Technical data**

Size 4 BZFM	$M_{SN}$ Nm	$M_0$ Nm	$n_0$ rpm	$n_{zn}$ rpm	$U_n^*$ V DC	$P_k$ W	airgap min/max	W kJ	$P_{vn}$ kW	J kgm <sup>2</sup>	m kg
6,3	63	69	6000	3300	110	110	0.4/1.2	80	0.16	0.0012	23
10	100	110	6000	3000	110	122	0.4/1.2	100	0.21	0.0019	32
16	160	175	6000	2700	110	142	0.4/1.2	120	0.26	0.0026	40
25	250	275	5500	2100	110	164	0.4/1.2	150	0.31	0.0050	56
40	400	440	4700	1800	110	214	0.4/1.5	220	0.38	0.0133	73
63	630	690	4000	1500	110	249	0.4/1.8	300	0.46	0.0271	107
100	1000	1100	3600	1300	110	332	0.5/2.1	350	0.57	0.0366	138
160	1600	1750	3200	1100	110	403	0.5/2.4	400	0.70	0.0600	205
250	2500	2750	2800	1000	110	530	0.5/2.8	590	0.85	0.1266	275
400	4000	4400	2400	1000	110	675	0.5/2.8	698	0.85	0.2670	380
630	6300	6930	2200	800	110	698	0.5/2.8	776	0.90	0.4700	506
1000	10,000	11,000	2000	700	110	827	0.6/3.0	844	0.95	0.7777	636

\* other voltages on request

## 4 BZFM – Electromagnetic Spring-Applied Brake

$M_{SN}$	Switchable nominal torque at 1 m/s frictional speed to DIN VDE 0580 (applies to dry operation with an oil- and grease-free friction lining after running-in)
$M_U$	Transmissible static nominal torque without slip, to DIN VDE 0580 (applies to dry operation with an oil- and grease-free friction lining after running-in)
$n_0$	Maximum idling speed
$n_{zn}$	Admissible switching speed
$P_k$	Excitation output at 20°C
$P_{vn}$	Nominal braking capacity (S4-40 % I.O.)
$W$	Switch work per switching operation for $z = 1 - 5h^{-1}$
$J$	Mass moment of inertia of rotating parts
$m$	Weight
Mode of operation	S1, S2, S4-40 % I.O.
Thermal class	155 (F) in accordance with DIN VDE 0580
AC-control	Via rectifier

**Table 2: List of dimensions (all dimensions in mm)**

Size 4 BZFM	6.3	10	16	25	40	63	100	160	250	400	630	1000
<b>a</b>	250	250	-	300	350	400	450	550	550	-	-	-
<b>a1</b>	300	300	300	350	400	450	550	660	660	660	800	800
<b>b</b>	215	215	-	265	300	350	400	500	500	-	-	-
<b>b1</b>	265	265	265	300	350	400	500	600	600	600	740	740
<b>c (H7)</b>	180	180	-	230	250	300	350	450	450	-	-	-
<b>c1 (H7)</b>	230	230	230	250	300	350	450	550	550	550	680	680
<b>d<sub>min</sub></b>	28	28	38	38	38	48	48	60	65	90	90	100
<b>d<sub>max</sub></b>	40	40	55	55	60	75	75	110	125	140	160	180
<b>f</b>	82	86	98	104	130	149	144	190	210	210	233	275
<b>h</b>	252	275	296	322	376	426	458	532	574	654	737	800
<b>j</b>	193	214	233	256	306	356	380	450	491	559	615	690
<b>k</b>	13.5	13.5	-	13.5	17.5	17.5	17.5	17.5	17.5	-	-	-
<b>k1</b>	13.5	13.5	13.5	17.5	17.5	17.5	17.5	22	22	22	22	22
<b>l</b>	-	147	-	165	196	196	209	-	274	-	-	-
<b>l1</b>	126	141	145	165	184	184	203	232	252	305	358	381
<b>n</b>	6	6	6	6	6	6	6	7	6	7	7	7
<b>p</b>	70	70	80	80	90	100	100	130	171	205	245	245
<b>s</b>	-	15	-	15	22	22	19	-	29	-	-	-
<b>s1</b>	-	11	-	11	12	12	16	-	22	-	-	-
<b>s2</b>	18	20	20	26	22	22	29	24	29	30	37	33

Keyways to DIN 6885/1  
Standard flange to DIN 42948



# 4 BZFM – Electromagnetic Spring-Applied Brake

## Optional Accessories

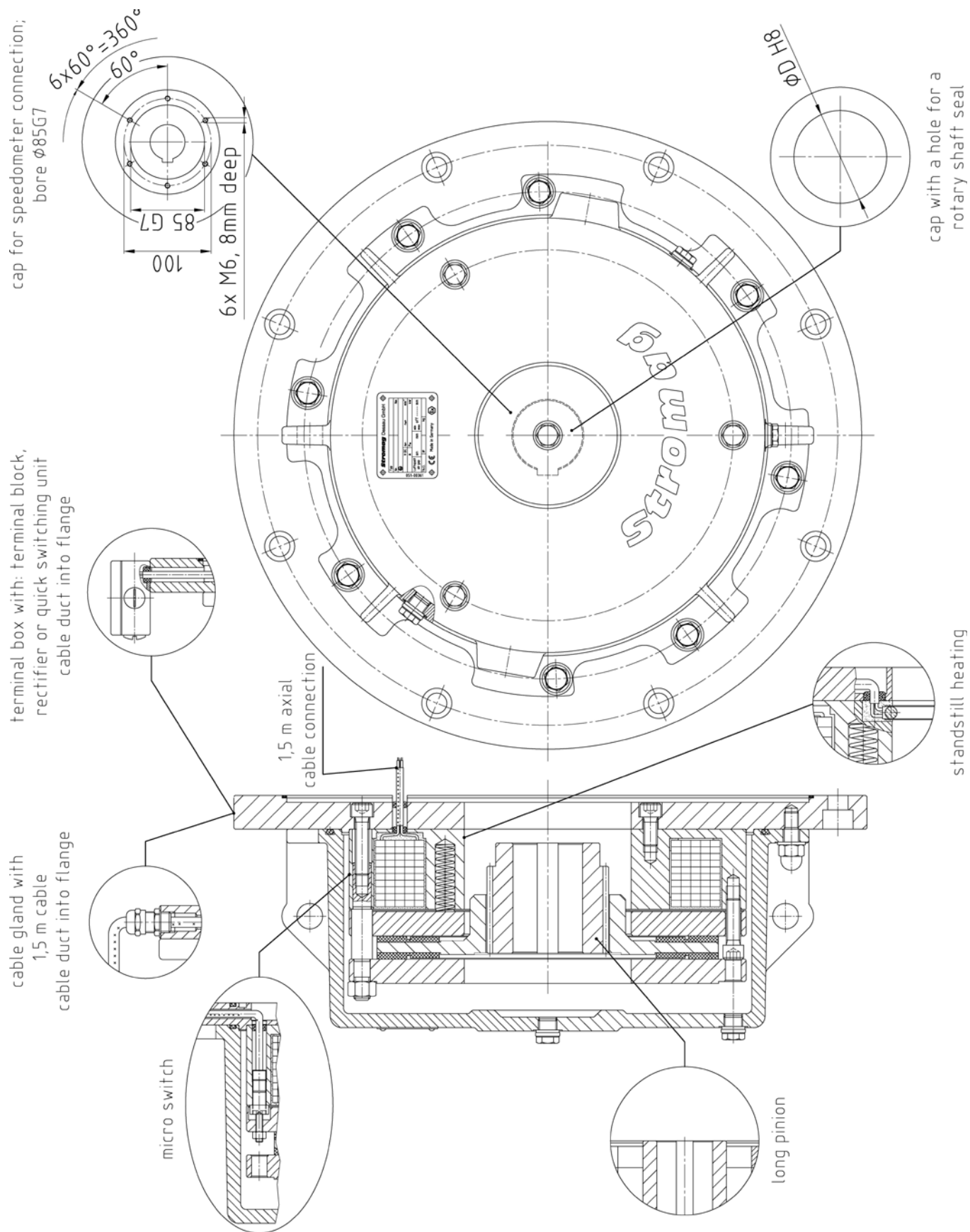

# 4 BZFM – Electromagnetic Spring-Applied Brake

## Example of designation

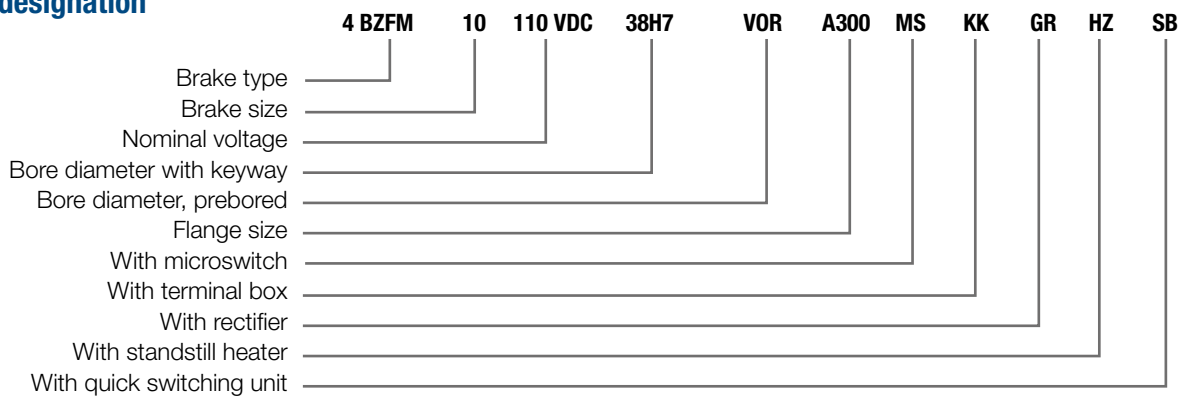

## Calculations

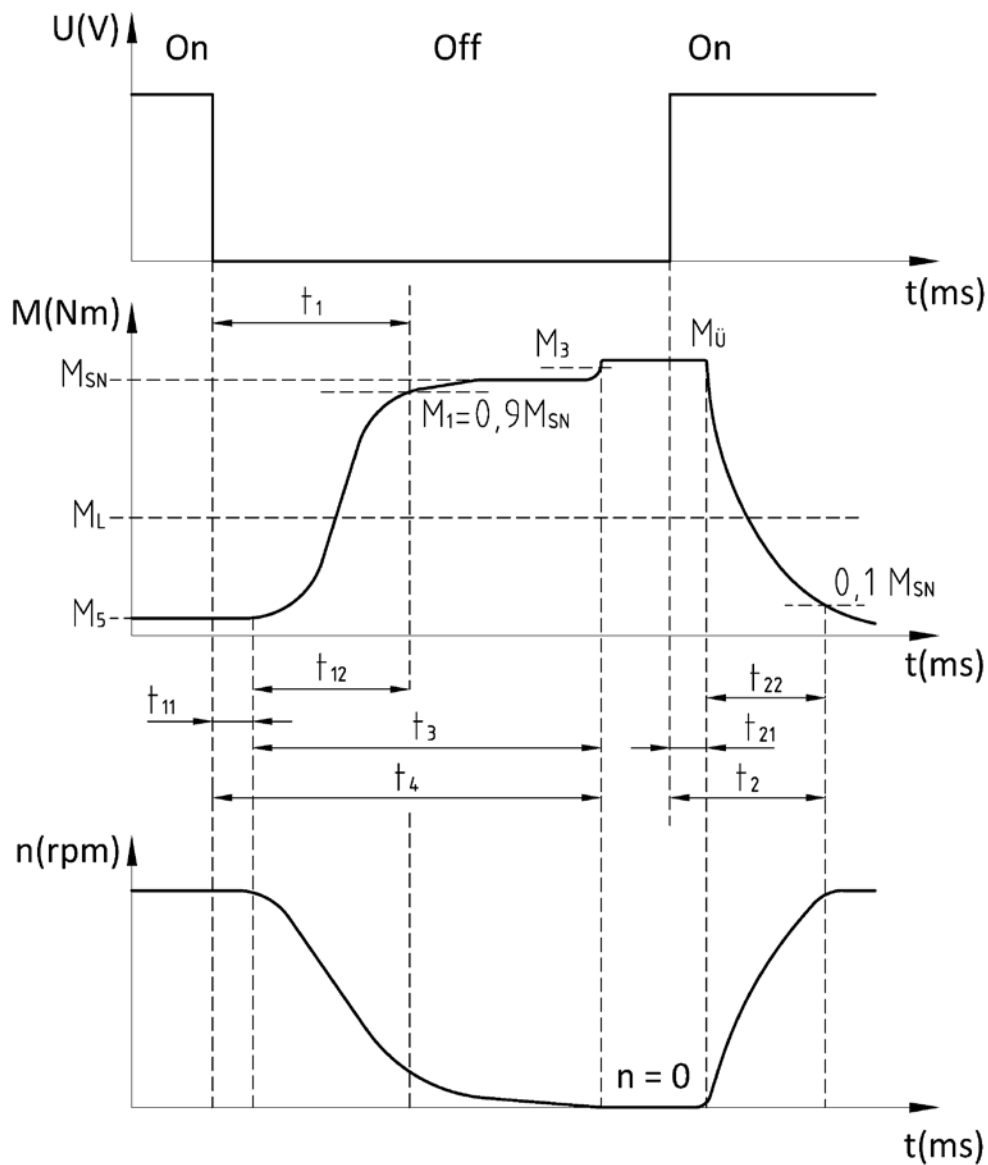

Figure 1:  
The diagram shows the time response of an Electromagnetic Spring-Applied Brake as defined by VDE regulations 0580

# 4 BZFM – Electromagnetic Spring-Applied Brake

## $M_1 =$ Switchable torque [Nm]

The switchable (dynamic) torque is the torque which can be transmitted by a brake under slip condition depending on the friction coefficient and at working temperature. ( $M_1 = 0,9M_{SN}$ )

## $M_3 =$ Synchronization torque [Nm]

The synchronization torque is the torque which arises for a short time after finishing the switching process.

## $M_{\bar{u}} =$ Transmissible torque [Nm]

The transmissible (static) torque is the max. torque that can be applied to a brake without the risk of slipping.

## $M_{SN} =$ Switchable nominal torque [Nm]

The switchable nominal torque is the dynamic torque as stated in the catalogue at a frictional speed of 1 m/sec.

## $M_L =$ Load torque [Nm]

+  $M_L$  for acceleration, –  $M_L$  for deceleration. The load torque should always be considered with relative safety factors.

## $M_5 =$ No-load torque (drag torque) [Nm]

The no-load torque is the torque which the brake transmits at working temperature when free running.

## $M_A =$ Decelerating torque [Nm]

The decelerating torque results from the addition (subtraction for lifting gear during lowering) of the switchable torque and load torque.

## Operation times

The operation times shown in the diagram are based on the example of a brake actuated by loss of electrical current. The basic characteristic is also applicable to brakes with alternate methods of operation.

The time delay  $t_{11}$  is the time from the instant of de-energization (actuation) to the commencement of the torque build-up (of no importance for d.c. switching). The torque build-up time  $t_{12}$  is the time from the commencement of torque build-up to the attainment of 90% of the switchable nominal torque  $M_{SN}$ . The switching time  $t_1$  is the sum of the time delay and torque build-up time:

$$t_1 = t_{11} + t_{12}$$

The time delay  $t_{21}$  is the time from energization (actuation) to the commencement of the torque will decrease. The fall time  $t_{22}$  is the time from the commencement of the torque decrease to 10% of the switchable nominal brake torque  $M_{SN}$ . The switching time  $t_2$  is the sum of the time delay and the fall time:

$$t_2 = t_{21} + t_{22}$$

To decrease the switching times of Electromagnetic Spring-Applied brakes, special switching is required.

Please ask for particular information. The switching times stated in the dimensional tables apply to d.c. switching, working temperature and nominal voltage without special switching techniques.

# 4 BZFM – Electromagnetic Spring-Applied Brake

## Nomenclature

$A_R$	cm <sup>2</sup>	Friction surface		
$m$	kg	Mass		
$Q$	Joule(J)	Heat quantity		
$Q_h$	Watt(W)	Heat per hour		
$c$	$\frac{kJ}{kgK}$	Specific heat	Steel $c = 0,46 \frac{kJ}{kgK}$	Cast iron $c = 0,54 \frac{kJ}{kgK}$
$n$	rpm	Speed		
$t_A$	s	Braking time		
$t_S$	s	Slipping time		

## Mass moment of inertia J [kgm<sup>2</sup>]

The mass moment of inertia J stated in the formula is the total mass moment of inertia of all the masses to be retarded referred to the brake.

## Reduction of moments of inertia

The reduction of moments of inertia is calculated from the formula

$$J_1 = J_2 * \left(\frac{n_2}{n_1}\right)^2 \quad [\text{kgm}^2]$$

## Moments of inertia of linear masses

The equivalent moment of inertia  $J_{Ers}$  for a linear mass  $m$  and a velocity  $v$  referred to the brake speed  $n$  is calculated from the formula

$$J_{Ers} = 91 * m \left(\frac{v}{n}\right)^2 \quad [\text{kgm}^2]$$

$[v = \text{m/s}] \quad [n = \text{min}^{-1}] \quad [m = \text{kg}]$

## Torque considerations for the brake

The mean torque of the driving or driven machine may be calculated from

$$M = 9550 * \frac{P}{n} \quad [\text{Nm}]$$

$[P = \text{kW}] \quad [n = \text{rpm}]$

If the system includes gearing, all torques must be referred to the brake shaft. Depending on the type and functioning of the driving or driven machine resp. shock and peak loads are an important factor for the determination of brake sizes. If precise deceleration times are required a sufficient decelerating torque must already been taken into account when selecting the brake size on the torque rating. Considering the load torque direction, the following switchable nominal torque  $M_{sn}$  of a brake is attained (+ $M_L$  for lifting devices when lowering).

$$M_{sn} = M_A \pm M_L$$

## 4 BZFM – Electromagnetic Spring-Applied Brake

When expressing the decelerating torque  $M_A$  by means of the pulse principle, we obtain after corresponding conversion.

Acceleration by load	Brake support by load
$M_A = J * \frac{d\omega}{dt} \quad [\text{Nm}]$	$M_A = J * \frac{d\omega}{dt} \quad [\text{Nm}]$
$M_{SN} = \frac{J * n}{9,55 * t_A} + M_L \quad [\text{Nm}]$	$M_{SN} = \frac{J * n}{9,55 * t_A} - M_L \quad [\text{Nm}]$
$t_A = \frac{J * n}{9,55 * (M_{SN} - M_L)} \quad [\text{s}]$	$t_A = \frac{J * n}{9,55 * (M_{SN} + M_L)} \quad [\text{s}]$

It is assumed that the dynamic torque is achieved instantaneously. Note that the dynamic torque decreases with the speed.

### Considerations of dissipated energy

For all operations at speed with slip, dissipated energy is generated in the brake which is transformed into heat. The admissible amount of dissipated energy resp. power capacity must not be exceeded in order to avoid any inadmissible heating. Often the selection of the brake size upon the torque requirement only is not sufficient. Therefore it must always be checked whether the heat capacity of the brake is sufficient.

Generally the dissipated energy in a brake, slipping at time  $dt$  with its dynamic torque  $M_s$  at an angular speed  $\omega_s$  is:

$$dQ = M_s * \omega_s * dt$$

With  $\omega_s$  and conversion by means of the pulse principle the following dissipated energy amount is determined for a single deceleration process with existing load torque

Acceleration by load	Brake support by load
$Q = \frac{M_{SN}}{(M_{SN} - M_L)} * \frac{J * n^2}{182.000} \quad [\text{kJ}]$	$Q = \frac{M_{SN}}{(M_{SN} + M_L)} * \frac{J * n^2}{182.000} \quad [\text{kJ}]$

If a brake slips with constant slipping speed under operation, the dissipated energy is calculated from the formula

$$Q = 0,105 * 10^{-3} * M_s * n_s * t_s \quad [\text{kJ}]$$

### Working brake

The brake has to brake a shaft with switching frequency "X" from speed "Y" to speed zero and has to hold it.

### Holding brake with emergency stop function

The brake actuates with shaft speed zero and has to hold; in case of emergency, however, it must be able to brake from shaft speed "Y" to zero.

# 4 BZFM – Electromagnetic Spring-Applied Brake

## Permissible heat capacity at 1500 rpm

W [kJ] Switching operations  $z \left[ \frac{1}{h} \right]$  operations per hour

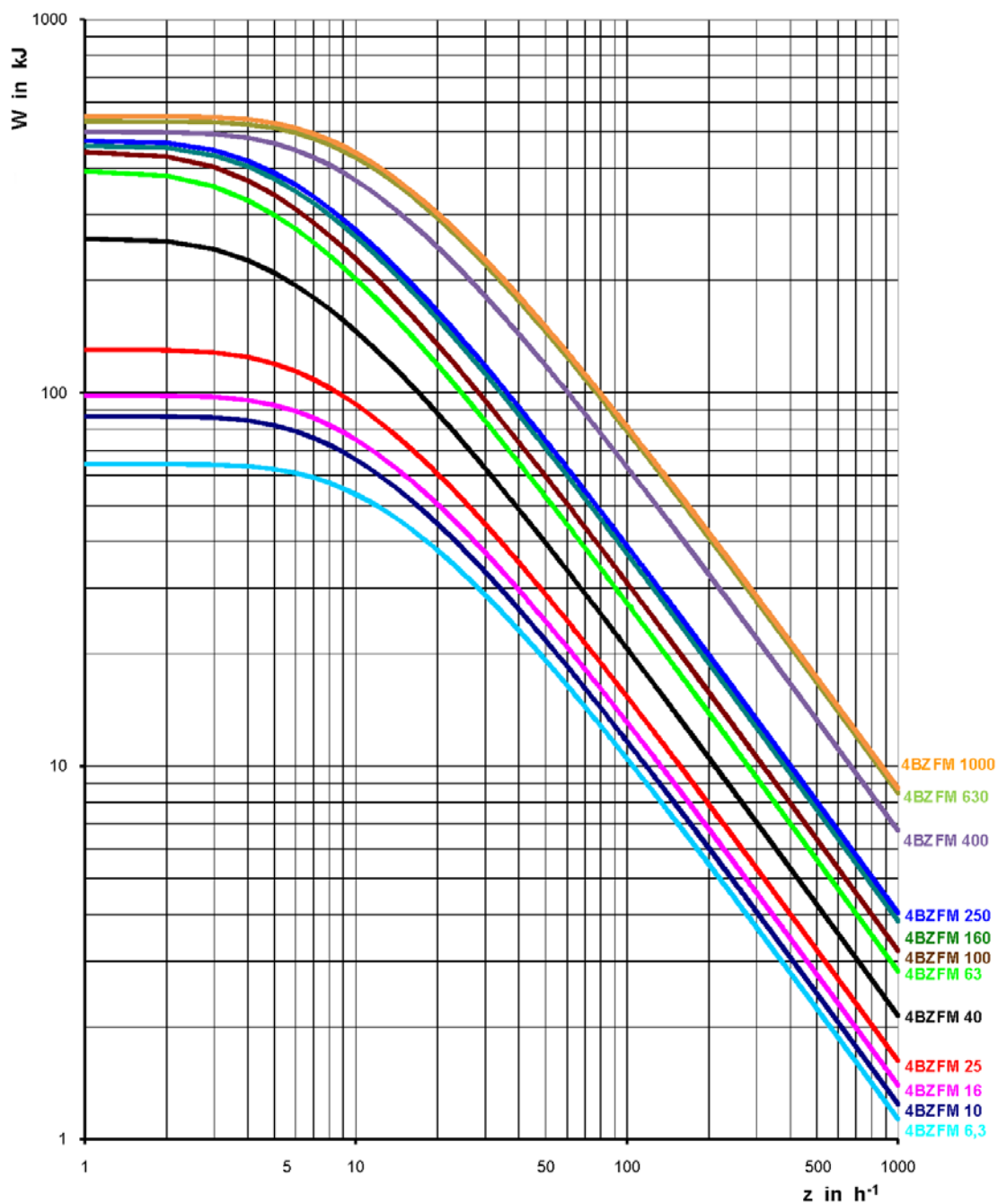

Figure 2: Heat capacity of series 4 BZFM n =1500 rpm \*\*.

By known operations and number of operations per hour the brake size can be obtained.

Example: W = 100 kJ/operation and z = 10 operations/hour choose the size 4 BZFM 40

\*\* permissible switching operations per switching at other speed ratings on request

# 4 BZFM – Electromagnetic Spring-Applied Brake

## Questionnaire to allow the determination of Spring-Applied Brakes

### DRIVING MACHINE

Frequency controlled motor		
Pole changing motor		
Constant speed motor		
Other motor types		
Nominal and maximum power		kW
Nominal and maximum speed		rpm
Maximum torque (i.e. breakdown torque)		Nm

### DRIVEN MACHINE

Slewing system		
Hoisting system		
Trolley or gantry system		
Winch system		
People transporting system		
Other application		

### BRAKE TYPE

Working and emergency brake		
Holding brake with emergency characteristic		

### CALCULATION DATA

Nominal braking speed		rpm
Emergency braking speed (i.e. max. possible overspeed at hoisting drives)		rpm
Load torque at nominal braking speed		Nm
Load torque at emergency braking speed		Nm
Maximum possible load torque		Nm
Number of braking operations per hour at nominal / required speed (incl. load data)		
Number of braking operations per required time unit at emergency speed (incl. maximum load data)		
Moment of inertia of the parts moved by the motor or braked by the brake (motor, gearbox, winch etc.)		kgm <sup>2</sup>
Demanded switching cycles of the brake		
Ambient temperature		°C
Protection class or short description of environmental conditions Marine, port, in house		
Options: Microswitch, rectifier, switching unit, terminal box, heater or other		

## Stromag Facilities

### Europe

#### Germany

Hansastraße 120  
59425 Unna - Germany  
+49 (0) 23 03 102 0

*Clutches & Brakes, Couplings,  
Geared Cam Limit Switches, Discs,  
Wind Brakes*

Dessauer Str. 10  
06844 Dessau-Roßlau - Germany  
+49 (0) 340 2190 0

*Electromagnetic Clutches & Brakes*

#### France

Avenue de l'Europe  
18150 La Guerche sur L'Aubois - France  
+33 (0)2 48 80 72 72

*Disc Brakes & Drum Brakes*

#### Great Britain

Ampthill Road  
Bedford, MK42 9RD - UK  
+44 (0)1234 324347

*Electromagnetic Clutches & Brakes,  
Industrial Caliper Brakes*

### North America

#### USA

31 Industrial Park Road  
New Hartford, CT 06057 - USA  
860-238-4783

*Electromagnetic Clutches & Brakes*

300 Indiana Highway 212  
Michigan City, IN 46360 - USA  
219-874-5248

*Couplings*

2800 Fisher Rd.  
Wichita Falls, TX  
940-723-3400

*Geared Cam Limit Switches,  
Industrial Caliper & Drum Brakes*

### Asia Pacific

#### China

T40B -5, No. 1765 Chuan Qiao Road  
Pudong 201206, Shanghai - China  
Tel +86 21-60580600

*Clutches & Brakes, Electromagnetic  
Clutches & Brakes, Couplings, Industrial  
Caliper & Drum Brakes, Discs, Geared  
Cam Limit Switches, Wind Brakes*

#### India

Gat No.: 448/14, Shinde Vasti, Nighoje  
Tal Khed, Pune- 410 501  
+91 2135 622100

*Clutches & Brakes, Electromagnetic  
Clutches & Brakes, Couplings, Industrial  
Caliper & Drum Brakes, Discs, Geared  
Cam Limit Switches, Wind Brakes*

## The Brands of Altra Industrial Motion

### Couplings

**Ameridrives**  
[www.ameridrives.com](http://www.ameridrives.com)

**Bibby Turboflex**  
[www.bibbyturboflex.com](http://www.bibbyturboflex.com)

**Guardian Couplings**  
[www.guardiancouplings.com](http://www.guardiancouplings.com)

**Huco**  
[www.huco.com](http://www.huco.com)

**Lamiflex Couplings**  
[www.lamiflexcouplings.com](http://www.lamiflexcouplings.com)

**Stromag**  
[www.stromag.com](http://www.stromag.com)

**TB Wood's**  
[www.tbwoods.com](http://www.tbwoods.com)

### Geared Cam Limit Switches

**Stromag**  
[www.stromag.com](http://www.stromag.com)

### Electric Clutches & Brakes

**Inertia Dynamics**  
[www.idicb.com](http://www.idicb.com)

**Matrix**  
[www.matrix-international.com](http://www.matrix-international.com)

**Stromag**  
[www.stromag.com](http://www.stromag.com)

**Warner Electric**  
[www.warnerelectric.com](http://www.warnerelectric.com)

### Linear Products

**Warner Linear**  
[www.warnerlinear.com](http://www.warnerlinear.com)

### Engineered Bearing Assemblies

**Kilian**  
[www.kilianbearings.com](http://www.kilianbearings.com)

### Heavy Duty Clutches & Brakes

**Industrial Clutch**  
[www.indclutch.com](http://www.indclutch.com)

**Twiflex**  
[www.twiflex.com](http://www.twiflex.com)

**Stromag**  
[www.stromag.com](http://www.stromag.com)

**Svendborg Brakes**  
[www.svendborg-brakes.com](http://www.svendborg-brakes.com)

**Wichita Clutch**  
[www.wichitaclutch.com](http://www.wichitaclutch.com)

### Belted Drives

**TB Wood's**  
[www.tbwoods.com](http://www.tbwoods.com)

### Gearing

**Bauer Gear Motor**  
[www.bauergears.com](http://www.bauergears.com)

**Boston Gear**  
[www.bostongear.com](http://www.bostongear.com)

**Delroyd Worm Gear**  
[www.delroyd.com](http://www.delroyd.com)

**Nuttall Gear**  
[www.nuttallgear.com](http://www.nuttallgear.com)

### Overrunning Clutches

**Formsprag Clutch**  
[www.formsprag.com](http://www.formsprag.com)

**Marland Clutch**  
[www.marland.com](http://www.marland.com)

**Stieber**  
[www.stieberclutch.com](http://www.stieberclutch.com)

Neither the accuracy nor completeness of the information contained in this publication is guaranteed by the company and may be subject to change in its sole discretion. The operating and performance characteristics of these products may vary depending on the application, installation, operating conditions and environmental factors. The company's terms and conditions of sale can be viewed at <http://www.altramotion.com/terms-and-conditions/sales-terms-and-conditions>. These terms and conditions apply to any person who may buy, acquire or use a product referred to herein, including any person who buys from a licensed distributor of these branded products.

©2018 by Stromag LLC. All rights reserved. All trademarks in this publication are the sole and exclusive property of Stromag LLC or one of its affiliated companies.